

5.1-5.8GHz PANEL 13 dBi FOR N FEMALE

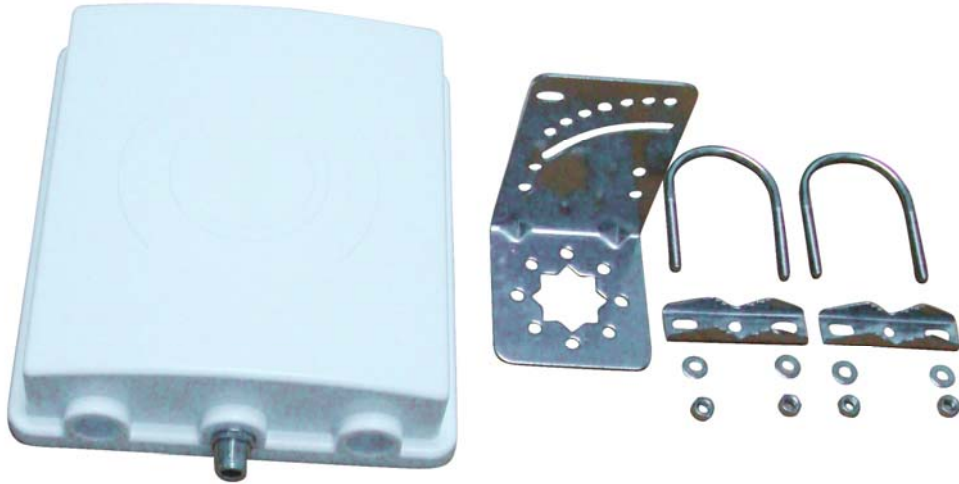

Specifications/Special Features :

This antenna is designed for wifi wireless communications

Specification	
Model No.	PA-5158-01
Frequency Range	5100~5800 MHz
Impedance	50 Ω
V.S.W.R.	<1.6
Gain	13 dBi
Maximum Power -W	100
Polarization	Vertical
Beam width deg.	Horz.29° Vert.27°
Standard Connector	N Female
Radome Material	ABS polymer (white)
Weight	1 kg
Dimensions	L223×W200×H60 mm

PA-5158-01

5.1-5.8 GHz PANEL 13 dBi FOR N FEMALE

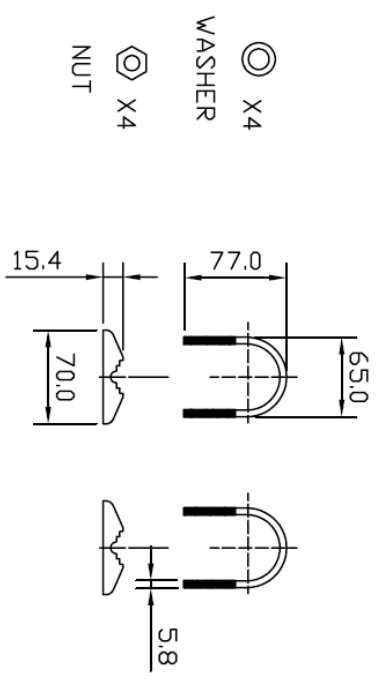
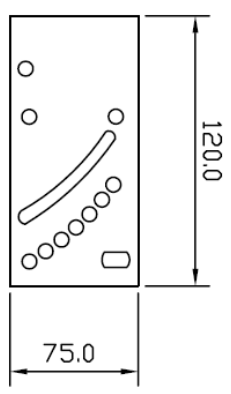
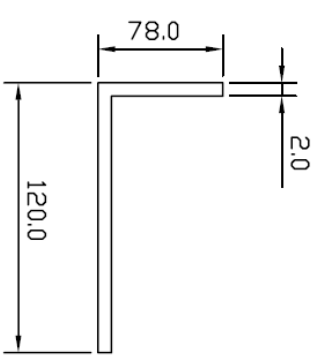
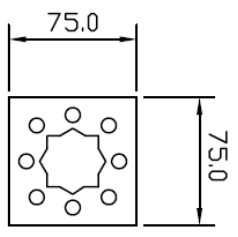
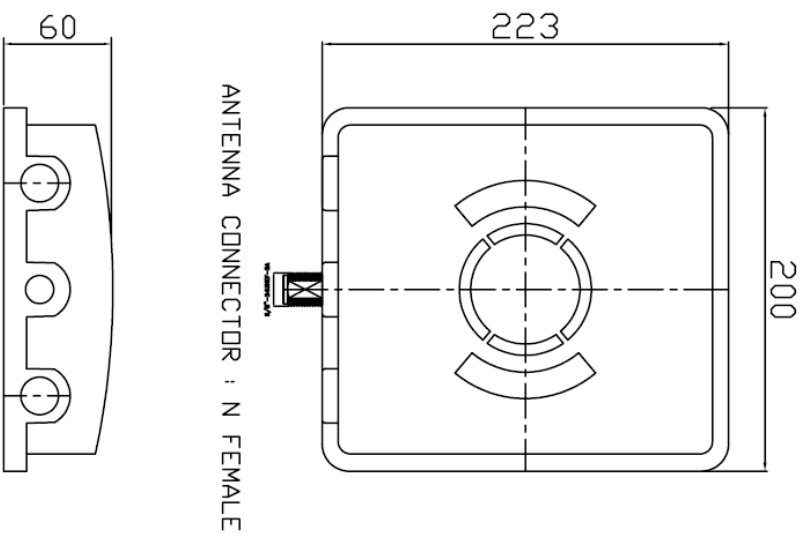

1	FREQUENCY RANGE : 5100-5800 MHZ	8	Dimensions : L223XW200XH60mm
2	GAIN : 13 dBi	9	
3	VSWR : < 1.6 : 1	10	
4	IMPEDANCE : 50 Ω	11	
5	POLARIZATION : LINEAR VERTICAL	12	
6	Antenna Connector : N FEMALE	13	
7	Maximum Power : 100W		

Trc1 S11 dB Mag 5 dB / Ref 0 dB Cal Offs
Mem2[Trc1] S11 dB Mag 5 dB / Ref 0 dB Invisible

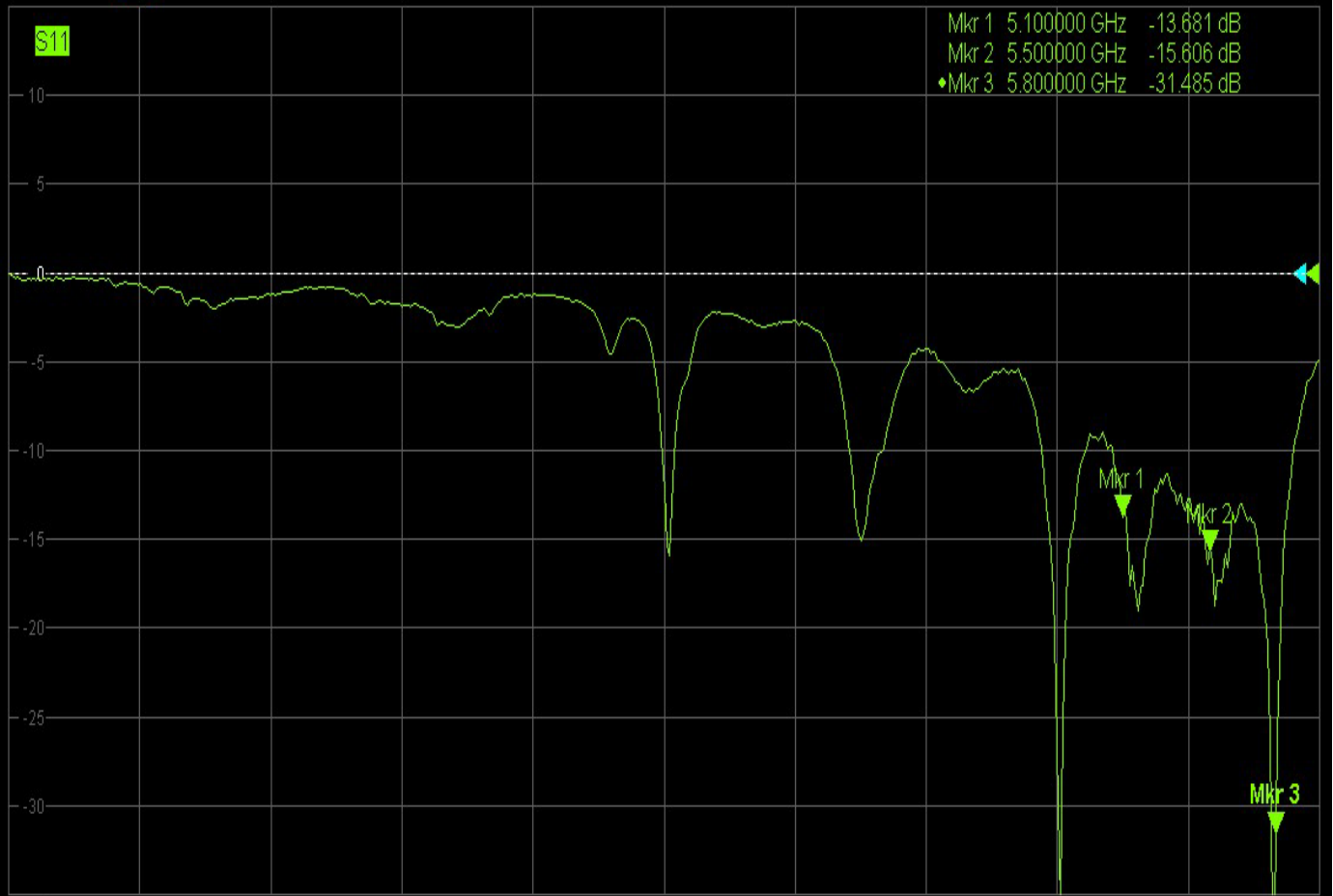

Ch1 Start 9 kHz Pwr 0 dBm Stop 6 GHz

Trc1 S11 SWR 1 U / Ref 1 U Cal Offs Mem2[Trc1] S11 SWR 1 U / Ref 1 U Invisible

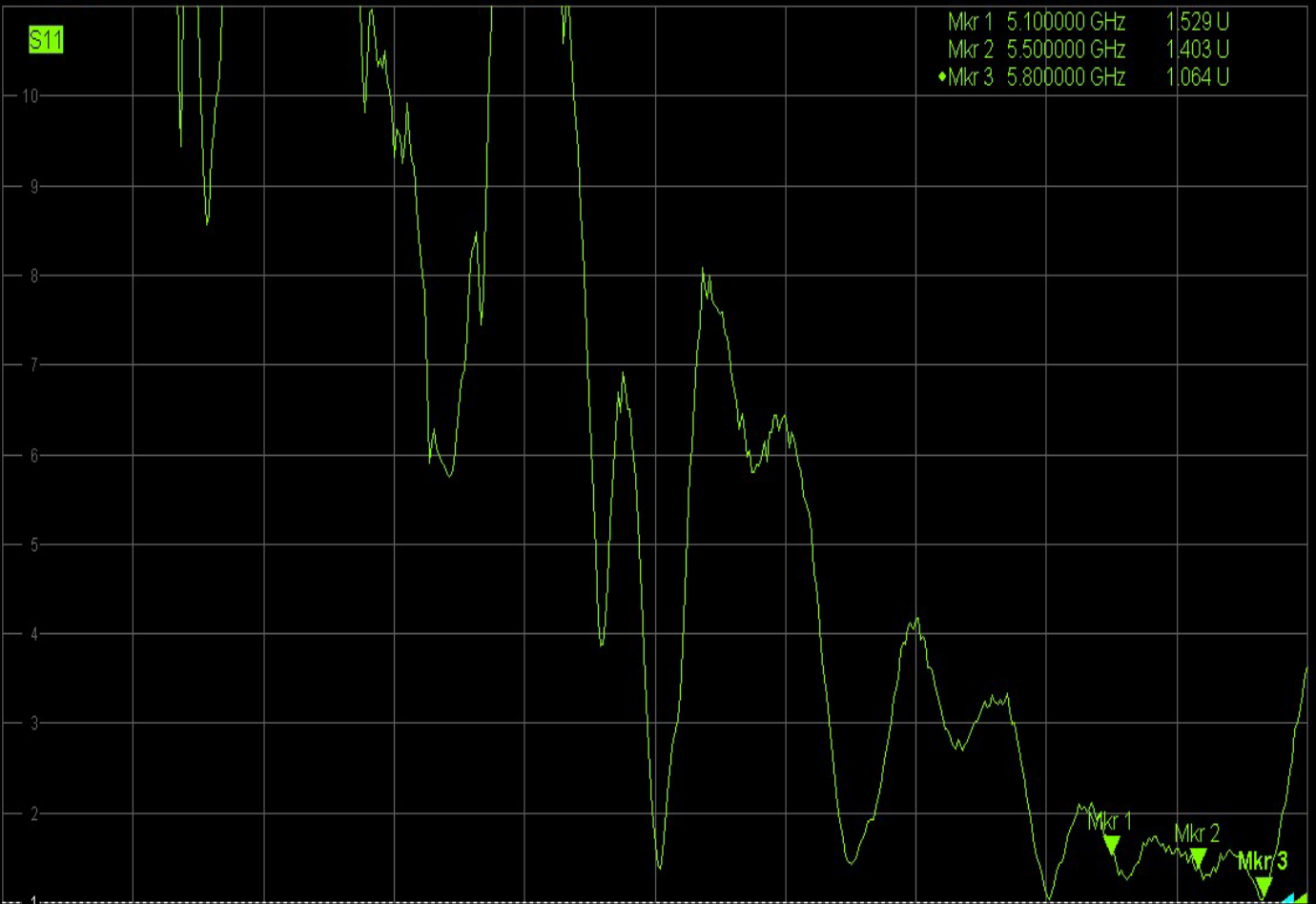

Ch1 Start 9 kHz Pwr 0 dBm Stop 6 GHz

H-PLANE

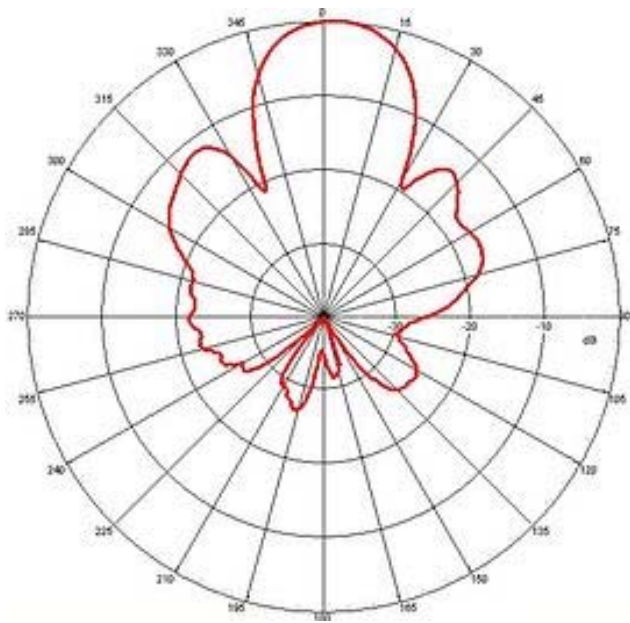

E-PLANE

